

# TECHNICAL REVIEW

No. 1 – 2009

## Use of Volume Velocity Sound Source in FRF Measurements Turnkey Free-field Reciprocity System

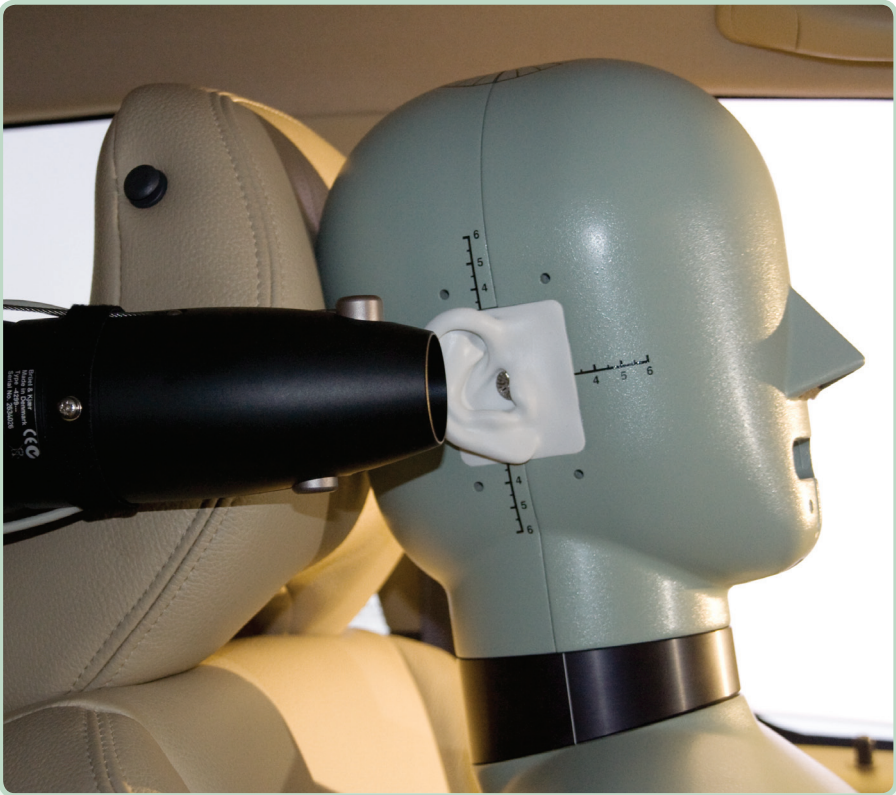

[www.bksv.com](http://www.bksv.com)

## Previously issued numbers of Brüel & Kjær Technical Review

- 1–2008 ISO 16063–11: Primary Vibration Calibration by Laser Interferometry:  
Evaluation of Sine Approximation Realised by FFT  
Infrasound Calibration of Measurement Microphones  
Improved Temperature Specifications for Transducers with Built-in  
Electronics
- 1–2007 Measurement of Normal Incidence Transmission Loss and Other Acoustical  
Properties of Materials Placed in a Standing Wave Tube
- 1–2006 Dyn-X Technology: 160 dB in One Input Range  
Order Tracking in Vibro-acoustic Measurements: A Novel Approach  
Eliminating the Tacho Probe  
Comparison of Acoustic Holography Methods for Surface Velocity  
Determination on a Vibrating Panel
- 1–2005 Acoustical Solutions in the Design of a Measurement Microphone for  
Surface Mounting  
Combined NAH and Beamforming Using the Same Array  
Patch Near-field Acoustical Holography Using a New Statistically Optimal  
Method
- 1–2004 Beamforming
- 1–2002 A New Design Principle for Triaxial Piezoelectric Accelerometers  
Use of FE Models in the Optimisation of Accelerometer Designs  
System for Measurement of Microphone Distortion and Linearity from  
Medium to Very High Levels
- 1–2001 The Influence of Environmental Conditions on the Pressure Sensitivity of  
Measurement Microphones  
Reduction of Heat Conduction Error in Microphone Pressure Reciprocity  
Calibration  
Frequency Response for Measurement Microphones – a Question of  
Confidence  
Measurement of Microphone Random-incidence and Pressure-field  
Responses and Determination of their Uncertainties
- 1–2000 Non-stationary STSF
- 1–1999 Characteristics of the vold-Kalman Order Tracking Filter
- 1–1998 Danish Primary Laboratory of Acoustics (DPLA) as Part of the National  
Metrology Organisation  
Pressure Reciprocity Calibration – Instrumentation, Results and Uncertainty  
MP.EXE, a Calculation Program for Pressure Reciprocity Calibration of  
Microphones
- 1–1997 A New Design Principle for Triaxial Piezoelectric Accelerometers  
A Simple QC Test for Knock Sensors  
Torsional Operational Deflection Shapes (TODS) Measurements
- 2–1996 Non-stationary Signal Analysis using Wavelet Transform, Short-time  
Fourier Transform and Wigner-Ville Distribution

*(Continued on cover page 3)*

# Technical Review

No. 1 – 2009

# Contents

Use of Volume Velocity Sound Sources in the Measurement of Acoustic Frequency Response Functions .....	1
<i>By Andreas P. Schuhmacher and Gijs Dirks</i>	
Turnkey Free-field Reciprocity System for Primary Microphone Calibration...	23
<i>By Erling Frederiksen</i>	

## TRADEMARKS

OmniSource is a trademark of Brüel & Kjær Sound & Vibration Measurement A/S.

Copyright © 2009, Brüel & Kjær Sound & Vibration Measurement A/S

All rights reserved. No part of this publication may be reproduced or distributed in any form, or by any means, without prior written permission of the publishers. For details, contact: Brüel & Kjær Sound & Vibration Measurement A/S, DK-2850 Nærum, Denmark.

Editor: Harry K. Zaveri

# Use of Volume Velocity Sound Sources in the Measurement of Acoustic Frequency Response Functions

*By Andreas P. Schuhmacher and Gijs Dirks*

## Abstract

In applications where acoustic radiation from a complicated sound source has to be modelled, a series of FRFs (Frequency Response Functions) of sound pressure/volume velocity ( $p/Q$ ) are normally measured. By combining operating acoustic source strengths with the FRFs, the airborne contributions of the modelled sound sources can be determined. In the case of structure-borne noise, a series of FRFs of sound pressure/force ( $p/F$ ) are measured. By measuring the operating forces acting on a structure and combining them with these FRFs, the noise contribution at a receiver position can be estimated. To determine the  $p/Q$  and  $p/F$  Frequency Response Functions, the device under test is repeatedly excited in different positions using a Volume Velocity Source, whilst there are no other forms of excitation.

This paper describes the design of a Volume Velocity Source and verifies its use in the measurement of  $p/Q$  FRFs. Two designs of Volume Velocity Source are presented, one for low-mid frequencies, and one for mid-high frequencies, both taking advantage of the two-microphone technique for estimating volume velocity at the orifice during operation.

## Résumé

Dans le cadre des applications où le rayonnement acoustique diffusé par une source sonore complexe doit être modélisé, on mesure généralement une série de fonctions FRF (fonctions de réponse en fréquence) de la vitesse pression acoustique/volume ( $p/Q$ ). En combinant les atouts de la source acoustique opérationnelle avec les FRFs, on peut alors déterminer les contributions au bruit aérien des sources sonores modélisées. Une série de fonctions FRF pression acoustique/force ( $p/F$ ) sont mesurées pour le bruit propagé par la structure. En mesurant les forces agissant sur la structure et en les combinant avec ces FRFs, il

est possible d'estimer la contribution sonore au point de réception. Pour déterminer les fonctions de réponse en fréquence  $p/Q$  et  $p/F$ , l'objet testé subi des excitations répétées sur différents points de sa structure au moyen d'une source omnidirectionnelle Volume Velocity Source, à défaut d'autres formes d'excitation.

La présente communication décrit comment est conçue cette Volume Velocity Source et rapporte les modalités de son utilisation pour des mesures de FRFs  $p/Q$ . Deux variantes de cette source sont présentées, une pour les fréquences basses à moyennes, l'autre pour les fréquences moyennes à hautes, toutes deux intégrant la technique des deux microphones pour une estimation de la vitesse volumique en sortie en cours d'opérations.

## Zusammenfassung

Bei Anwendungen, bei denen die akustische Strahlung einer komplizierten Schallquelle modelliert werden muss, wird in der Regel eine Serie von Übertragungsfunktionen (FRF) von Schalldruck/Volumengeschwindigkeit ( $p/Q$ ) gemessen. Durch Kombination der akustischen Betriebs-Quellstärken mit den FRFs lassen sich die Luftschallbeiträge der modellierten Schallquellen bestimmen. Bei Körperschall wird eine Serie von Schalldruck/Kraft-FRFs ( $p/F$ ) gemessen. Durch Messung der Betriebskräfte, die auf eine Struktur einwirken, und Kombination mit diesen FRFs lässt sich der Geräuschbeitrag an einer Empfängerposition abschätzen. Zur Ermittlung der Übertragungsfunktionen  $p/Q$  und  $p/F$  wird das zu prüfende Gerät wiederholt in verschiedenen Positionen angeregt, wobei die Anregung ausschließlich durch eine Volumengeschwindigkeitsquelle erfolgt.

Dieser Artikel beschreibt den Aufbau einer Volumengeschwindigkeitsquelle und verifiziert ihre Anwendung bei der Messung von  $p/Q$ -FRFs. Es werden zwei Bauarten der Volumengeschwindigkeitsquelle vorgestellt: eine für tiefe bis mittlere Frequenzen und eine für mittlere bis hohe Frequenzen. Beide profitieren von der Zweimikrofon-Technik zur Abschätzung der Volumengeschwindigkeit an der Öffnung beim Betrieb.

## Introduction

To measure vibro-acoustic ( $p/F$ ) FRFs in a vehicle, we normally take advantage of the reciprocity principle by placing a volume velocity sound source inside the cabin at the receiver position and mounting an accelerometer at the input force location. Acoustic ( $p/Q$ ) FRFs, on the other hand, can be measured using either a direct or reciprocal approach with a microphone measuring the sound pressure at either the receiver location or at an assumed acoustic source position. However, for practical reasons, the type of FRFs from engine compartment source to cabin receiver position are usually measured reciprocally due to the limitation of space in engine compartments.

A volume velocity source has to meet some specific requirements [1]:

- The source should produce a sufficiently high sound level
- The frequency range covered should be appropriate
- The source should behave as a monopole in the frequency range of interest
- The output volume velocity should be measurable even when the acoustic environment changes

The acoustic source for this purpose must be powerful and omnidirectional and a signal proportional to the source strength must be available – if the source strength is not available directly. Furthermore, the frequency range covered should be as broad as possible. Most volume velocity sound sources use one microphone as a reference, assuming that there is a fixed linear relationship between volume velocity output and reference sound pressure at the microphone. To find this relationship, the sound source is operated in an anechoic room and the volume velocity output can be estimated from a microphone measurement at a known distance from the source. A frequency response function between volume velocity and reference sound pressure can then be calculated and stored for use when the source is used in the real environment. The influence of a changing environment on this fixed linear relationship will be investigated later in this paper by using some real measurements. For sound sources based on a driver (loudspeaker) where the sound radiates from the orifice of a flexible hose, the two-microphone method can be used to estimate the volume velocity output without first estimating the sound pressure to source strength relationship in the anechoic room. A further benefit of this approach is the ability to determine the output volume velocity in any acoustic environment.

## *Methods to Measure Volume Velocity of a Driver*

The following methods can be used:

- Single-microphone Method
- Two-microphone Method

### **Single-microphone Method**

A signal proportional to the volume velocity must be available as the volume velocity cannot be measured directly. Furthermore, the frequency range covered should be as broad as possible. Volume velocity sound sources using one microphone as a reference assume there is a fixed linear relationship between volume velocity output and reference sound pressure at the microphone. This relationship, however, is dependent on the impedance loading the sound source, which increases, especially in confined spaces.

Calibration under anechoic conditions is needed with this method, even though this calibration is not valid for all load impedances.

### **Two-microphone Method**

In an earlier paper [2], the principle behind a particular volume velocity sound source using two microphones was described in terms of how it was designed. An omnidirectional sound source (Brüel & Kjær Type 4295), which was already used for room acoustic applications, was chosen as ‘the driver’ together with a special adaptor (Brüel & Kjær Type 4299) that measures the volume velocity output. A pair of phase-matched microphones are used inside the adaptor to estimate the calibrated volume velocity output spectrum in situ.

Fig. 1 shows the sound source, together with the adaptor, placed inside an anechoic room, and Fig. 2 shows a practical measurement setup where a flexible

*Fig. 1. Low-mid frequency sound source (without extension hose)*



*Fig. 2. Low-mid frequency sound source (with extension hose)*

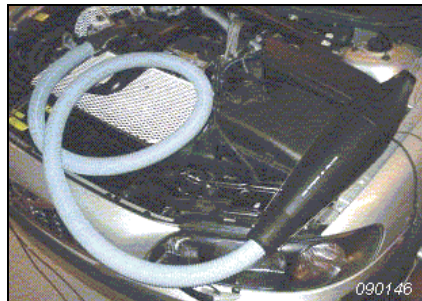



hose is mounted between the sound source and the adaptor for ease-of-use during measurements. As the useful frequency range of the driving loudspeaker is 50 Hz – 6 kHz, the output will be sufficient; however, the radiation from the orifice of the adaptor becomes more directional, i.e., less omnidirectional, above 2–3 kHz.

In the following section we review some of the basic concepts behind the two-microphone method, which has been widely used to measure acoustic properties in ducts [3, 4]. It is assumed that only plane waves are measured at two microphone positions A and B inside a cylindrical duct, see Fig. 3.

The sound pressure  $p(x)$  in a cross-section of the duct can then be expressed as:

$$p(x) = p_+ e^{-jkx} + p_- e^{jkx} \quad (1)$$

where  $p_+$  and  $p_-$  are the incident and reflected plane wave components respectively, and  $k$  is the wavenumber. By measuring the sound pressure inside the duct at the two different microphone positions, the unknown incident and reflected plane wave components can be determined. Usually this is done by measuring the transfer function between the two microphones, which is why it is also referred to as the transfer function method.

The particle velocity evaluated in a cross-sectional area is given by:

$$u(x) = \frac{1}{\rho c} (p_+ e^{-jkx} - p_- e^{jkx}) \quad (2)$$

where  $\rho c$  is the characteristic impedance of air.

Fig. 3. Two-microphone measurement configuration for volume velocity output estimation

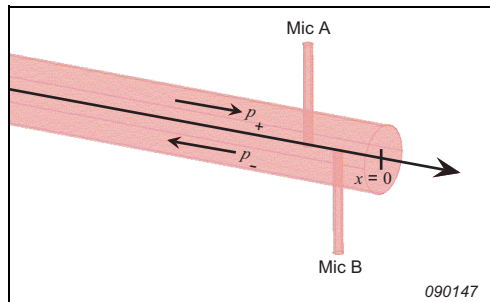

At the duct opening,  $x = 0$ , we have:

$$u(0) = \frac{1}{\rho c} (p_+ - p_-) \tag{3}$$

and the output volume velocity signal  $Q$  can then be found by multiplication with the cross-sectional area  $S$  of the duct. Higher order modes in the duct opening have zero volume velocity and therefore do not contribute. Finally, the frequency response function  $p/Q$  to a response pressure  $p$  can be written as:

$$H_{Qp} \equiv \frac{p}{Q} = \frac{P}{\frac{S}{\rho c} (p_+ - p_-)} \tag{4}$$

### *Frequency Response Function Measurement with the Two-microphone Volume Velocity Method*

The source to be used for reciprocal FRF measurements must be powerful and omnidirectional, and the frequency range of interest is typically 50–8000 Hz.

Fig. 4 shows the Volume Velocity measurement adaptor fitted onto the Type 4295 OmniSource™ Sound Source. Notice the 1/4" intensity microphone pair built into the adaptor. The cylindrical tube section with a diameter of 4 cm will suppress all non-planar waves at the microphones up to approximately 5 kHz. The

*Fig. 4. Volume Velocity measurement adaptor for OmniSource Type 4295*

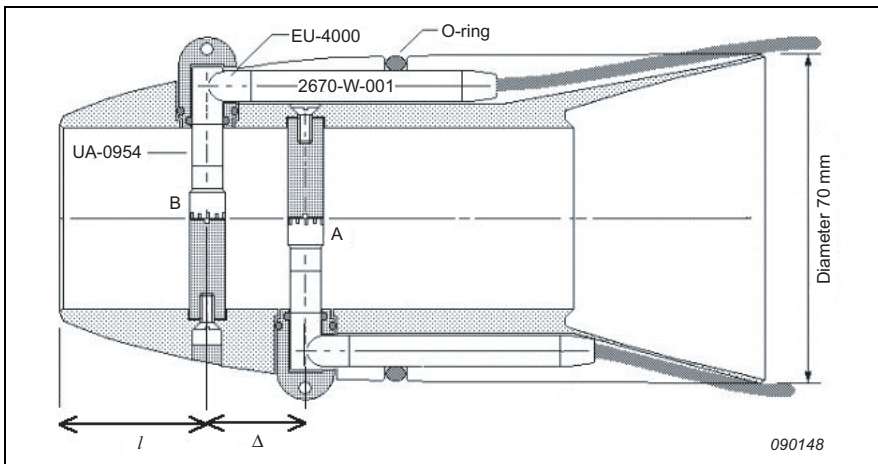

first higher order mode has a single radial node line and can propagate above 5 kHz. But by measuring the pressure on the tube axis, this mode should not be detected (in principle), as can be seen by the fact that it does not contribute to the output Volume Velocity. The first higher order mode, which has non-zero pressure on the axis, can propagate only above 10.4 kHz. At 6 kHz this mode will be attenuated 41 dB over the 3 cm from the opening to the outermost microphone B. Thus, if the two microphones (A and B) could measure the undisturbed pressure exactly on the axis, then only the propagating plane waves would contribute significantly to the measurement over the frequency range dealt with. In practice, the microphones will disturb the sound field and not measure the pressure exactly on the axis.

The pressure is measured at the two microphones  $p_A$  and  $p_B$ . The response at a position  $R$  is also measured. From these signals the cross-spectral matrix can be built, as shown in Table 1.

Table 1. Cross-spectral matrix

	<b>A</b>	<b>B</b>	<b>R</b>
<b>A</b>	$C_{AA}$	$C_{AB}$	$C_{AR}$
<b>B</b>		$C_{BB}$	$C_{BR}$
<b>R</b>			$C_{RR}$

The autospectrum of the Volume Velocity ( $C_{QQ}$ ) in the opening of the adaptor and the cross-spectrum ( $C_{QR}$ ) between the Volume Velocity and the response signal can be shown to be [2]:

$$C_{QQ} = \left(\frac{S}{\rho c}\right)^2 \frac{C_{AA}\cos^2(kl) + C_{BB}\cos^2(k(l+\Delta)) - 2Re\{C_{AB}\}\cos(kl)\cos(k(l+\Delta))}{\sin^2(k\Delta)} \quad (5)$$

$$C_{QR} = \frac{S}{\rho c} \frac{C_{AR}\cos(kl) - C_{BR}\cos(k(l+\Delta))}{j\sin(k\Delta)} \quad (6)$$

where:

$S$  is the cross-sectional area of the tube

$l$  see Fig. 4, typically 3 cm

$\Delta$  see Fig. 4, typically 2 cm

$k$  wave number ( $2\pi f/c$ )  
 $\rho$  is the air density  
 $c$  is the propagation speed of sound

Using the two spectra, equations (5) and (6), the FRF  $H_{QR}$  between this Volume Velocity and the response signal can be obtained as:

$$H_{QR} = \frac{C_{QR}}{C_{QQ}} \tag{7}$$

## Applications for Measuring a Source’s Volume Velocity

### Introduction

In the automotive industry there is a growing need for measurement of acoustical FRFs in connection with transfer path analysis. With advances in electrical and hybrid vehicle development, new paths and sources in the Automotive NVH process need to be investigated and evaluated, the main outcome being acoustical source contribution analysis.

The analysis is used extensively to troubleshoot and to set targets at component level, as well as being used to evaluate the acoustic NVH performance of vehicles with the help of auralisation tools, such as the NVH Vehicle Simulator Type 8601.

### Application Example: Source Substitution

The source substitution method is used to evaluate component contribution. The FRFs in an existing vehicle are measured from modelled point source locations to the passenger positions, inside the cabin. The second step is to record operating data, which is used to estimate the source strength  $Q$  using a matrix formulation.

Fig. 5. Source substitution method

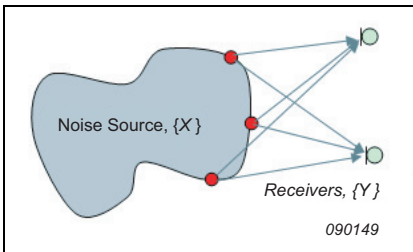
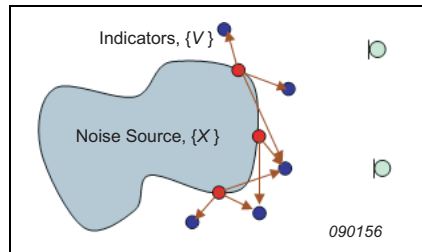

Fig. 6. Matrix method



The response at the receiver position is given by the product of source strength and FRF, in the frequency domain, see equation (8) and Fig. 5.

$$\{Y\} = [H_{xy}]\{X\} \quad (8)$$

where  $\{Y\}$  is a vector of spectra at the receiver positions,  $\{X\}$  is a vector of spectra of source strengths and  $[H_{xy}]$  is a matrix of FRFs measured between source positions and receiver positions.

Since the strengths of sources cannot be measured directly, they are typically estimated using the matrix method, see equations (9), (10) and Fig. 6:

$$\{V\} = [H_{xv}]\{X\} \quad (9)$$

$$\{X\} = [H_{xv}]^{-1}\{V\} \quad (10)$$

Some examples of typical results are shown in Fig. 7 and Fig. 8.

These figures show measured and predicted engine sound on one HATS (Head and Torso Simulator) channel using the source substitution method.

*Fig. 7. Measured HATS*

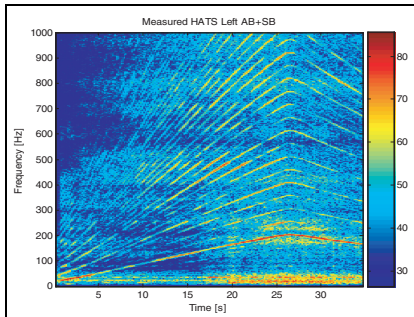

*Fig. 8. Predicted HATS*

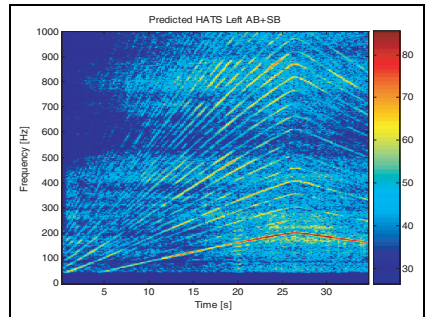

### *Reciprocity Methods*

The volume velocity source described so far has been used to measure acoustic FRF between an assumed source position inside an engine compartment and receiver positions inside the vehicle. Direct FRF measurements – from source at engine surface to microphones inside a vehicle – were compared to reciprocal measurements where the source, i.e., the hose orifice, was positioned at the

Fig. 9. Reciprocal measurement of acoustic ( $p/Q$ ) and vibro-acoustic ( $p/F$ ) transfer functions in a vehicle

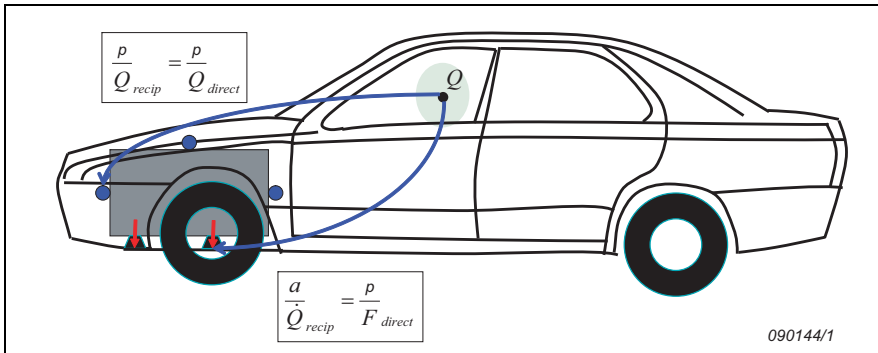

receiver and a microphone measuring the sound pressure at the engine surface position, see Fig. 9. For the vibro-acoustic FRF, reciprocity holds between  $p/F$  and acceleration/volume acceleration ( $a/Q$ ).

Since the receiver positions in the direct measurement consisted of microphones in the ears of a HATS, the reciprocal measurement should ideally be made with a HATS having sound sources placed at the entrance of the closed ear canals.

## Design of Volume Velocity Source

### Introduction

A volume velocity source has to meet some specific requirements [1]:

- The source should produce a sufficiently high sound level
- The frequency range covered should be appropriate
- The source should behave as a monopole in the frequency range of interest
- The output volume velocity should be measurable even when the acoustic environment changes

Besides these technical requirements, one may want to add some practical requirements, for instance that the source should be small enough to be used in confined spaces, for example, inside a tightly packed engine room. For airborne contribution analysis, a volume velocity source is used initially to provide acoustic FRFs between source positions close to the surface of the actual noise source and some near-field microphones located around the noise source. Therefore, to

measure FRFs easily it must be possible to attach the sound source on any surface or to position it in the near-field if a reciprocal approach is used. This speaks in favour of using a sound source based on some sort of driver attached to a long flexible hose where the sound is radiated from the hose orifice. The hose end can then be attached to a surface or placed in air during FRF measurements.

### *Design of a Low-mid Frequency Volume Velocity Source – Type 4299 Adaptor*

The OmniSource Sound Source Type 4295 (see Fig. 1) has been designed to provide a high level ( $L_w = 105$  dB re 1 pW) of omnidirectional sound radiation over a broad frequency range from around 60 Hz to 6.3 kHz. The target application was room acoustics measurements, so OmniSource was in many ways perfectly suited for the Volume Velocity application. The only feature missing was the capability to measure the Volume Velocity output and, in particular, the FRF from Volume Velocity output to the (pressure) response at a set of positions. The Volume Velocity measurement Adaptor Type 4299, which is fitted to Type 4295, is shown in Fig. 4 and Fig. 10.

Notice the  $\frac{1}{4}$ " intensity microphone pair (Types 4178) built into the adaptor. The cylindrical tube section with a diameter of 4 cm suppresses all non-planar waves at the microphones up to approximately 5 kHz. The first higher order mode has a single radial node line and can propagate above 5 kHz. However, by measuring the pressure on the tube axis, this mode should not be detected (in principle). This fits

*Fig. 10. Type 4295 (and Type 4299) positioned next to HATS right ear in a vehicle*

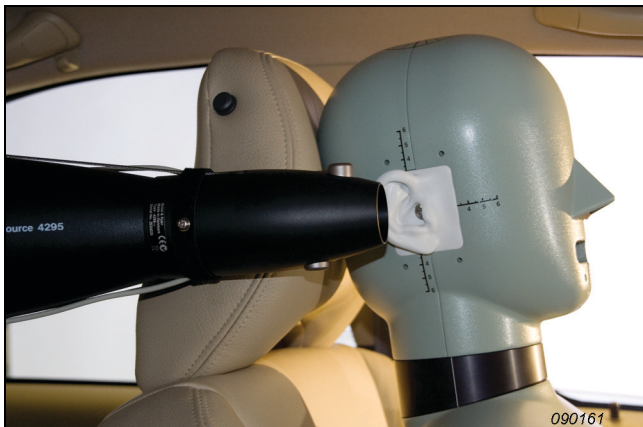

with the fact that it does not contribute to the output Volume Velocity. The first higher order mode, which has non-zero pressure on the axis, can only propagate above 10.4 kHz. At 6 kHz, this mode will be attenuated 41 dB over the 3 cm from the opening to the outermost microphone (microphone B). So if the two microphones (A and B) could measure the undisturbed pressure exactly on the axis, then only the propagating plane waves would contribute significantly to the measurement over the considered frequency range. In practice, the microphones will disturb the sound field and not measure the pressure exactly on the axis. So assuming that only plane waves are measured, the plane wave components propagating in the two directions can be estimated from the two microphone signals. These two plane wave components can be extrapolated to the opening of the tube, and the Volume Velocity output can be calculated.

### Measurement of Maximum SPL Output

Fig. 11 shows the 1/3-octave SPL spectrum measured exactly 10 cm in front of the aperture of the Volume Velocity Adaptor, when OmniSource Type 4295 is driven approximately at its maximum output with pink noise (the excitation was frequency band limited to the interval 0–6300 Hz). Fig. 12 shows the 400 line FFT

Fig. 11. 1/3-octave SPL spectrum at 10 cm, with maximum pink noise excitation

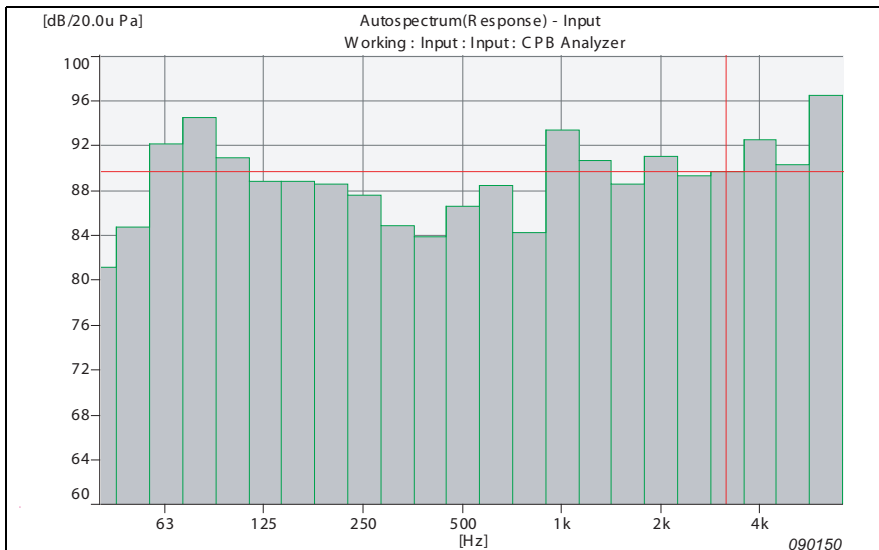
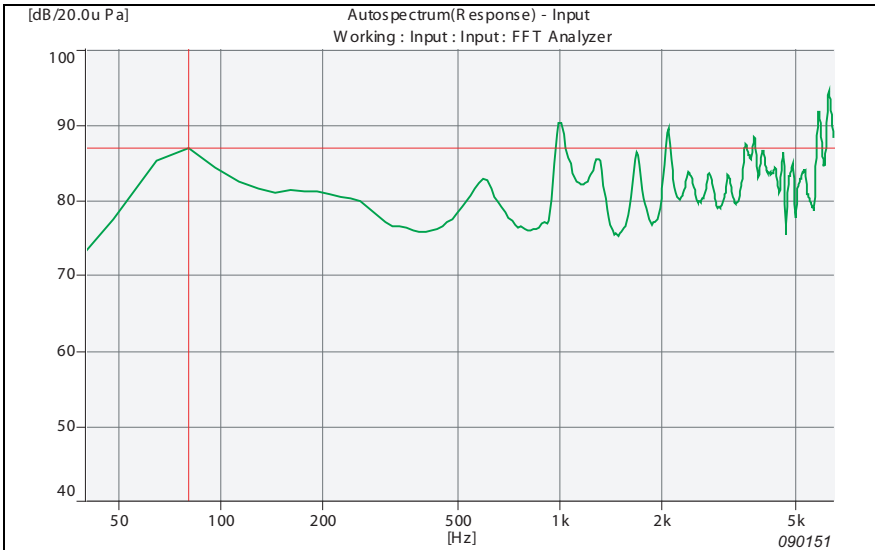



Fig. 12. 1/3-octave SPL spectrum at 10 cm, with maximum pink noise excitation



spectrum at 10 cm from the aperture when OmniSource Type 4295 is driven at its maximum output (approximately) with white noise. Notice that loudspeaker distortion is not critical, as the microphone and receiver are subjected to the same distortion – specifically with a frequency response function in that sound field. As can be seen, the Volume Velocity source has a reasonably flat output as a function of frequency.

### *Measurement of Directivity*

Two metres from the output aperture of the Volume Velocity Adaptor the 1/3-octave SPL spectrum was measured as a function of the off-axis angle with  $10^\circ$  intervals between the measurement points. Fig. 13 shows sequence of plots of the radiation patterns for the 1/3-octave bands 500, 1000, 2000, 2500, 3150 and 4000Hz.

Up to approximately 4 kHz, the SPL does not change more than 5 or 6 dB (approx.) over the  $360^\circ$  angle interval. At higher frequencies (not shown in the figure) it becomes more directive. Fig. 14 shows direct and reciprocal curve FRFs for engine top position to HATS left ear, and Fig. 15 shows the measurement setup on a Volvo engine.

Fig. 13. Directivity patterns from 500 Hz to 4 kHz

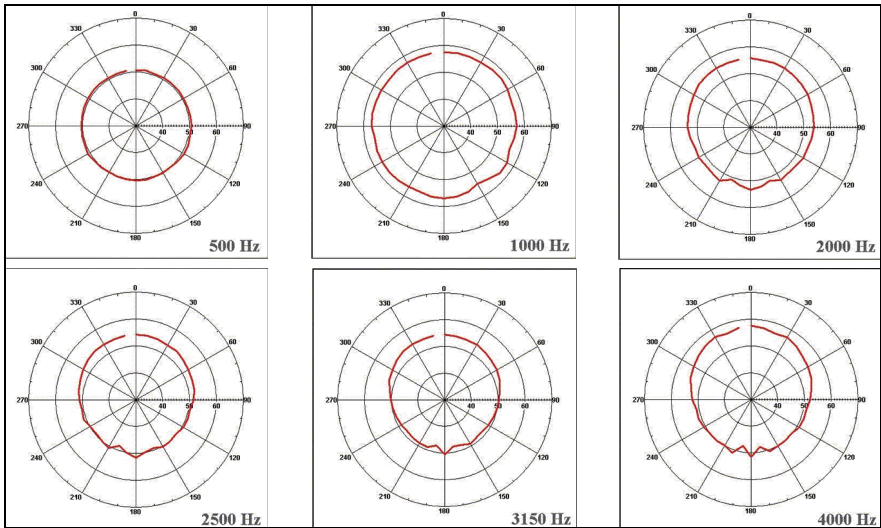

Fig. 14. FRFs: Engine top position to HATS left ear – direct (red curve) and reciprocal (blue) Top: 0–2 kHz. Bottom: 2–6 kHz

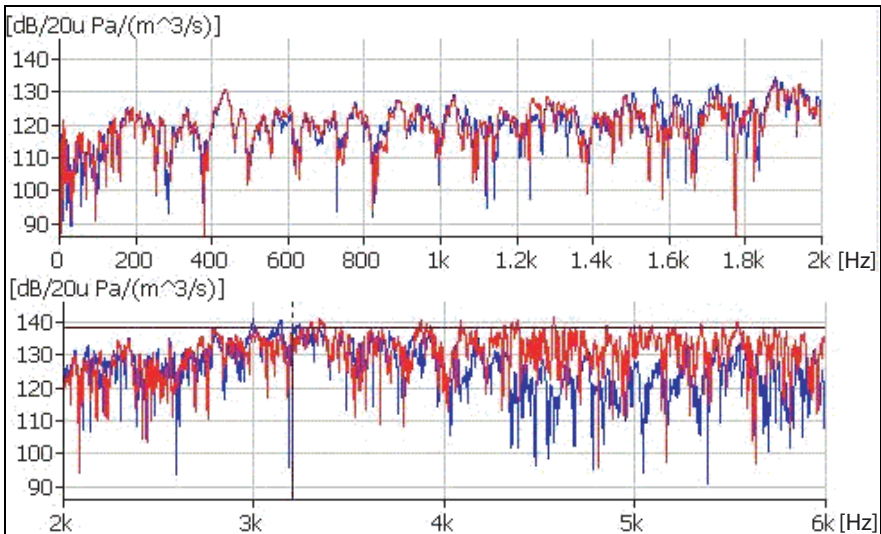

Fig. 15. Measurement setup on a Volvo engine



### *Design of a Small and Powerful High-frequency Volume Velocity Source*

Another newly developed sound source covering mainly mid-high frequencies and based on a similar principle has also been considered for comparison. The construction of the mid-high frequency sound source is made from a powerful compression driver and a long hose consisting of steel reinforced PVC. The inner diameter of the hose is 10 mm and a similar set of microphones is used, close to the opening, for estimating the true volume velocity output.

### *Numerical Simulation of the Mid-high-frequency Volume Velocity Source*

In this section we will verify the radiation characteristics of the mid-high-frequency sound source using numerical simulation tools. These tools can provide initial information about the performance of certain designs. In the current mid-high-frequency source, a new adaptor was designed for accommodating the two microphones necessary for the volume velocity estimation principle.

The new adaptor tends to have dimensions that are larger than the hose outer diameter. Therefore, it was decided to simulate the directivity of the sound source to understand if the behaviour is still monopole-like (omnidirectional) at high frequencies. A CAD drawing of the adaptor was used initially to perform a finite element simulation of the sound field outside the adaptor, when only the orifice vibrates as a piston, see Fig. 16 for the SPL distribution on the adaptor at 8 kHz.

Furthermore, we can simulate the sound pressure in the farfield and make a directivity plot to understand how the source radiates. Since the adaptor is not an axisymmetrical structure, the directivity in the vertical plane is different from the horizontal plane. See Fig. 17 for source directivity plots. The directivity plots for

Fig. 16. Finite element simulation of the sound pressure distribution on the two-microphone adaptor at 8 kHz

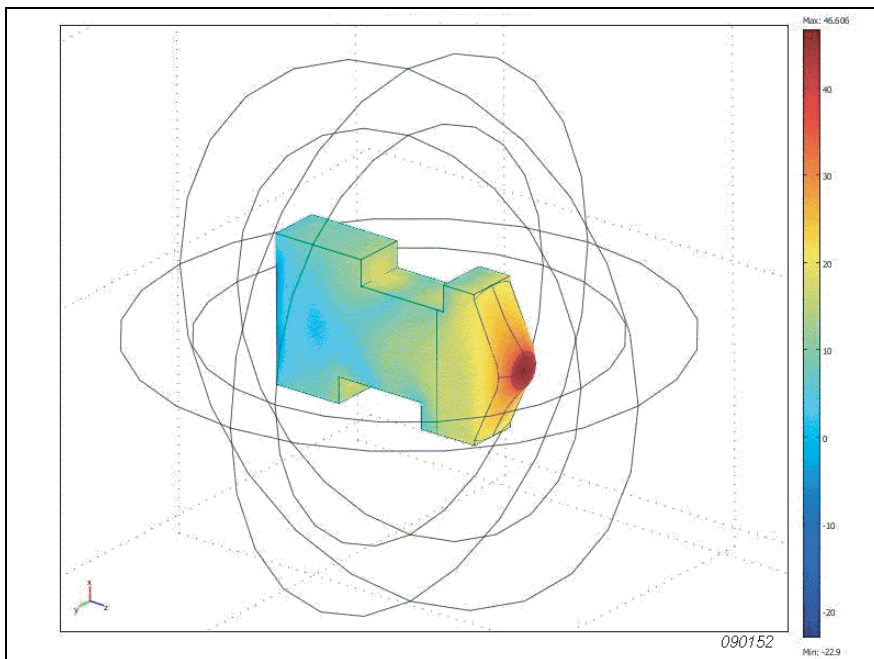

the adaptor design at this frequency (8 kHz) reveal that the source will still be reasonably omnidirectional within a few dB. At this frequency there is only a slight problem with radiation in the rear direction  $\pm 120/150$  degrees and you may notice that the source behaves differently in the horizontal and vertical planes, see Fig. 18.

### *Experimental Study of the Sound Sources*

A couple of measurements (see Fig. 19) were carried out in a real vehicle with each of the investigated sound sources for the same source position on the top engine surface. The receiver positions in the direct measurement consisted of microphones in the ears of a HATS placed in one of the front seats. The sources were controlled using a dedicated measurement template allowing set up of the individual source parameters like microphone spacing, hose inner diameter, etc.

Fig. 17. Source directivity plots

Top Left: 1 kHz, Top Right: 2 kHz, Bottom Left: 4 kHz, Bottom Right: 8 kHz

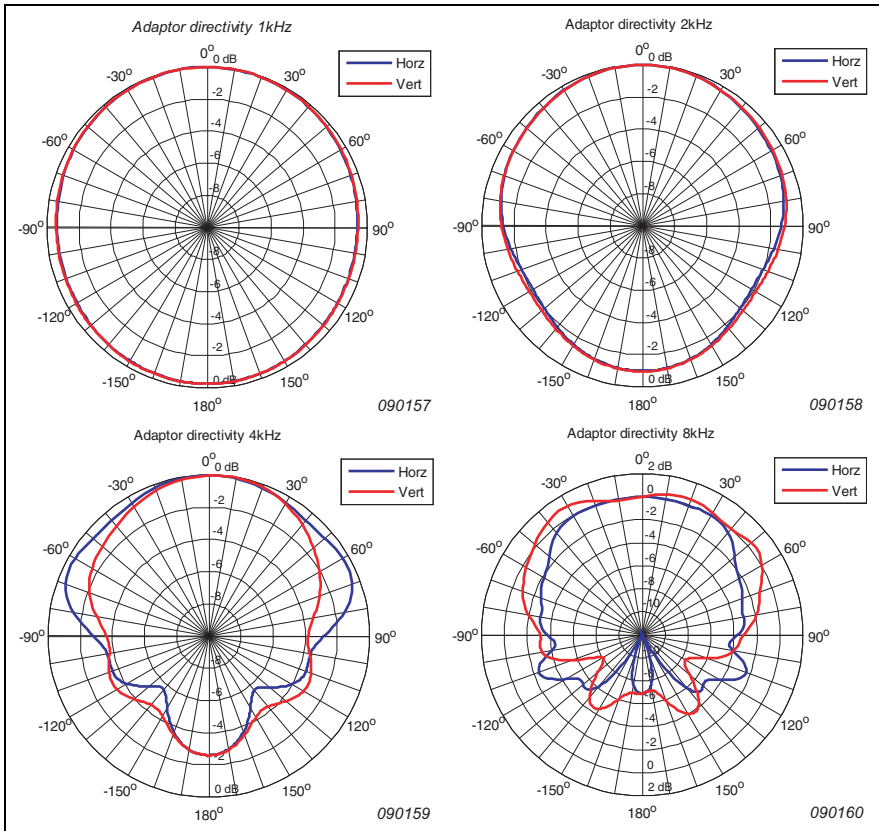

## Source Directivity

When comparing transfer functions from the same position but different orientations, the effects of the directivity of a source can be examined with respect to omnidirectionality. In Fig. 19 we compare FRFs measured with the mid-high-frequency sound source for different orientations of the adaptor, i.e., pointing towards the rear, front, left and right of the vehicle.

The measured FRFs can be seen to agree down to 200 Hz, where the output power from the horn driver itself starts to decrease significantly. We see similar FRFs for all four orientations and the trend is the same even at the highest

Fig. 18. Directivity at 100 mV rms driving voltage  
 Left: Horizontal plane, Right: Vertical plane

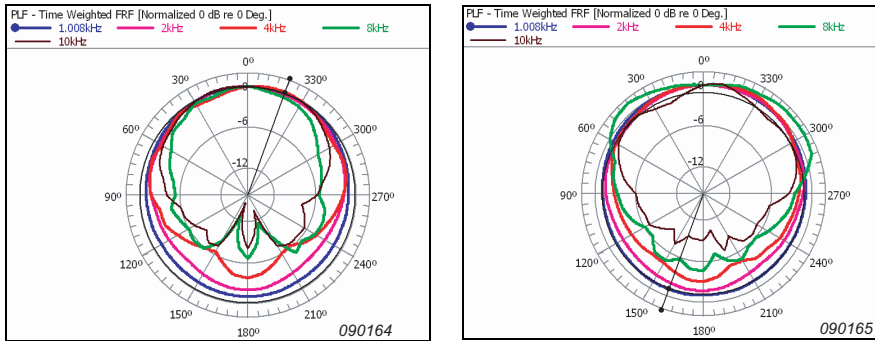
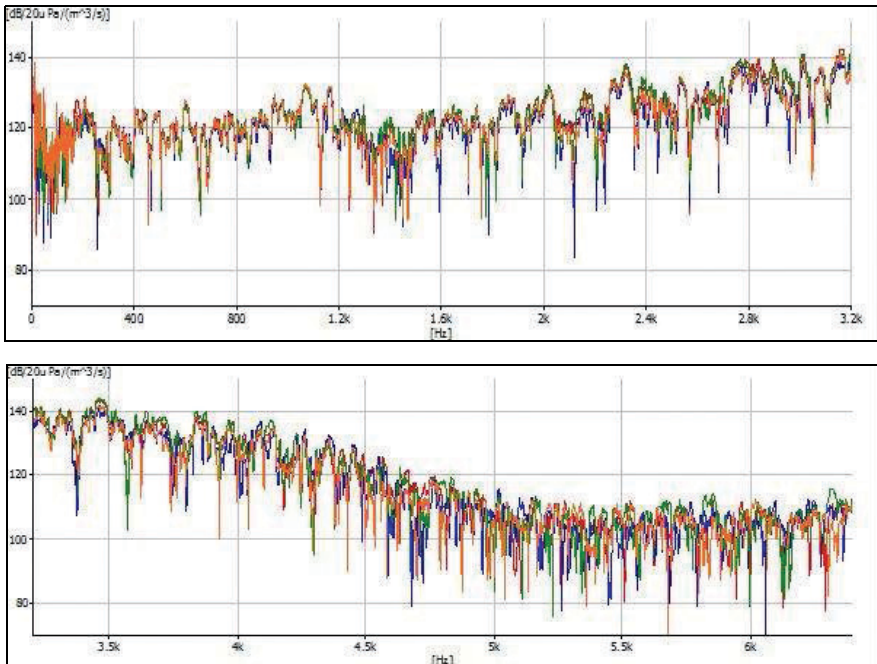

Fig. 19. Acoustic transfer functions measured between top engine position and HATS right ear for different adaptor orientations using mid-high-frequency sound source.  
 Top: 0 – 3.2 kHz. Bottom: 0 – 6400 Hz



frequencies shown, i.e., 6.4 kHz. Above this frequency the sound from the orifice of the adaptor becomes more directional as explained earlier, and the effect of this can be seen from the lower plot in Fig. 19.

### *Comparison of Sources*

Measuring the same direct FRFs from the top engine surface position to HATS ears is now investigated using the two sound sources. The low-mid-frequency sound source was driven by a white noise signal, band-limited to 6.4 kHz, whereas the mid-high-frequency sound source was driven by a similar white noise signal, high-pass filtered with cut-off at 600 Hz, in order not to overload the driver at low frequencies. FRFs measured with the orifice pointing towards the rear of the vehicle are compared below in the frequency ranges 0–1000 Hz and 0–6400 Hz for the amplitude characteristics. Even though the input signal for the mid-high-frequency sound source is high-pass filtered at 600 Hz, the FRFs obtained by this

*Fig. 20. Comparison of acoustic transfer functions measured between engine top and right ear position. Low-mid-frequency source (blue) and mid-high-frequency source (red). Top: 0–1000 Hz. Bottom: 0–6400 Hz.*

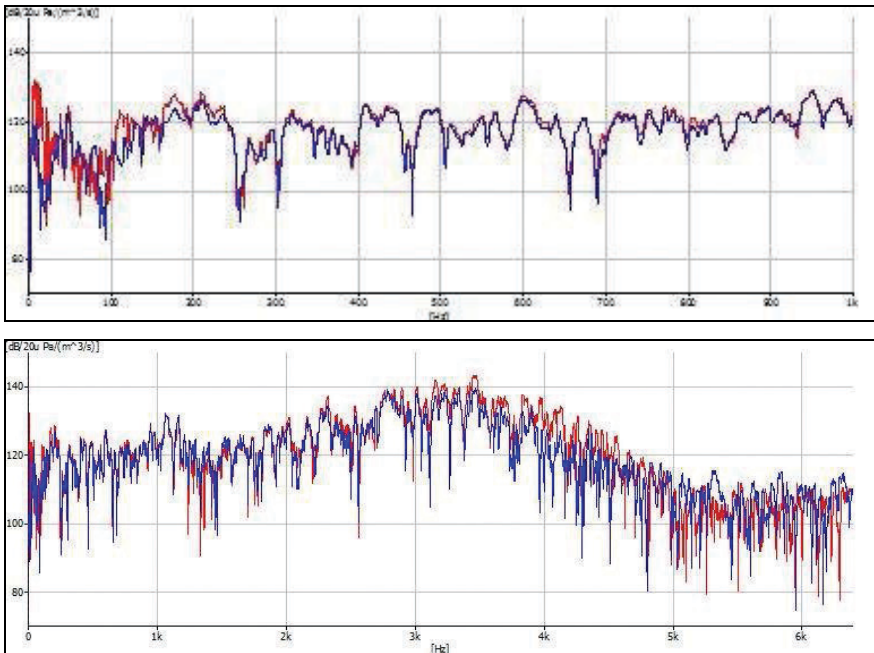

source are valid down to 200 Hz, since sufficient sound output is produced by the source compared to background noise levels. In Fig. 20 it can be seen that the measured FRFs using the two sound sources agree very well in amplitude from 200 Hz up to at least 3 kHz. The lower plot in Fig. 20 shows the amplitude in the frequency range 0–6400 Hz, where deviations are seen in the range of 10 dB at high frequencies. This is expected as the high-frequency source is omnidirectional to a much higher frequency than the low-frequency source and the dimensions of the sources (together with their different acoustic centres) play a role at higher frequencies and this introduces deviations.

### **Direct vs Reciprocal Measurement**

Furthermore, we compare FRFs measured in the direct sense to reciprocal FRFs. For reciprocal measurements, the HATS was still in place inside the vehicle, but now the sound source was placed as close as possible to one of the microphones inside the ears. Fig. 21 shows an example of how to locate the orifice of the adaptor just next to the concha part of the right pinna.

*Fig. 21. Positioning the adaptor of mid-high-frequency sound source next to HATS right ear for reciprocal frequency response function measurements*



For the reciprocal measurements a standard  $\frac{1}{2}$ " microphone was placed at the top engine surface position for measuring the blocked surface pressure. Ideally, the effect of hose and adaptor on the sound field locally around the engine surface position should be included by having those in place during reciprocal measurement, but this effect was ignored since it was not practical. (If this effect was to be included, an extra adaptor would have been necessary.) A comparison of direct and reciprocal measured FRFs is shown for the high-frequency source in Fig. 22.

Some deviations are expected at lower frequencies where the output of the source is limited, i.e., below 200 Hz. Also, the effect of having a poor signal-to-



noise ratio for the microphone at the source position will have an impact and we see this as a noisier reciprocal FRF below 400 Hz. As can be seen, there is good agreement between the two FRFs up to nearly 5 kHz. Above that frequency other

*Fig. 22. Direct (red curve) and reciprocal (blue curve) measurement of top engine surface to HATS left ear transfer function using mid-high-frequency source. Top: 0-1000 Hz. Bottom: 0-6400 Hz*

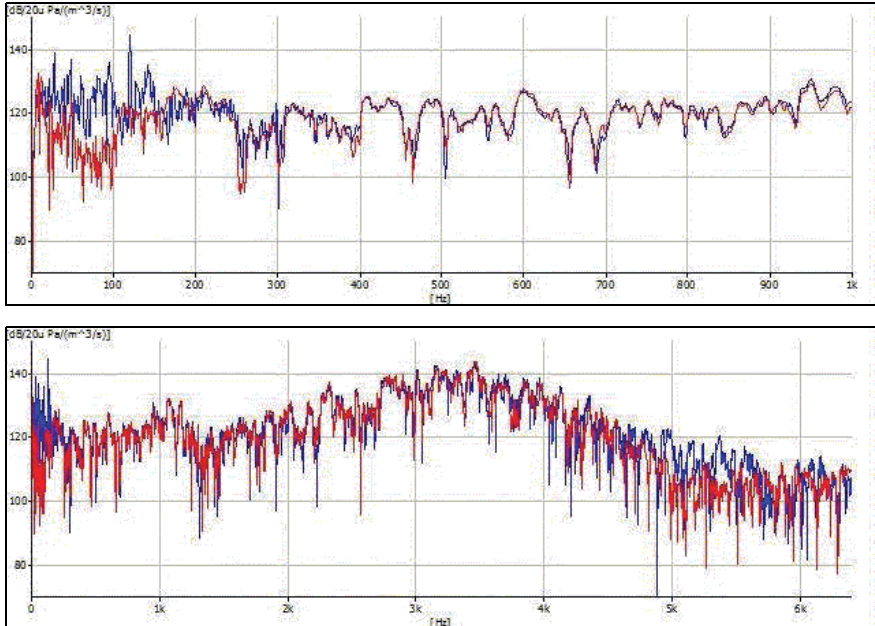

types of errors are introduced mainly due to incorrect positioning of the sound source for reciprocal measurement, i.e., the adaptor orifice is not placed at the entrance of the ear canal.

## Conclusions

Volume velocity sound sources for measuring acoustic and vibro-acoustic FRFs have been presented. Each type of sound source presented here was based on a powerful driver, which was attached to a long hose and equipped with two

microphones close to the orifice. They were used to measure the volume velocity source strength in situ.

FRFs could then easily be estimated. The principle was reviewed and some sources of errors related to current sound sources were pointed out. Acoustic FRFs were measured in a vehicle environment (with some confidence), proving that it is possible to reciprocally measure the binaural FRFs, by placing the orifice close to the entrance of the outer ear. In this case, a standard HATS and volume velocity source can be used to do all the operating and FRF measurements related to source-path-contribution analysis, including binaural effects. In addition, a sound source aimed at mid-to-high frequency measurements, making use of the two-microphone method, was investigated and compared to the current low-to-mid frequency sound source.

## References

- [1] F. H. van Tol, J. W. Verheij, “*Brite EuRam II: Loudspeaker for Reciprocal Measurement of Near Field Sound Transfer Functions on Heavy Road Vehicle Engines*”, TNO Institute of Applied Physics, Delft, The Netherlands, 1993.
- [2] S. Gade, N. Møller, J. Hald, L. Alkestrup, “*The Use of Volume Velocity Source in Transfer Measurements*”, Proc. 2004 Int. Conf. on Modal Analysis Noise and Vibration Engineering (ISMA), Leuven, pp. 2641-2648, 2004.
- [3] J. Y. Chung, D. A. Blaser, “*Transfer Function Method of Measuring In-duct Acoustic Properties*”. I. Theory, J. Acoustical Society of America, Vol. 68, No. 3, pp. 907-913, 1980.
- [4] H. Bodén, M. Åbom, “*Influence of Errors on the Two-microphone Method for Measuring Acoustic Properties in Ducts*”, Journal of the Acoustical Society of America, Vol. 79, No. 2, pp. 541-549, 1986.
- [5] P. M. Morse, K. U. Ingard, “*Theoretical Acoustics*”, McGraw-Hill, New York, 1968.
- [6] A. Schuhmacher, “*Practical Measurement of Transfer Functions using Volume Velocity Sources*”, DAGA, 2009.

# Turnkey Free-field Reciprocity System for Primary Microphone Calibration

*Erling Frederiksen*

## Abstract

Although most practical measurements are performed under free- or diffuse-field conditions, all reference microphone calibrations performed by national metrology institutes are essentially pressure response calibrations. Fortunately, as measurement microphones have fixed ratios between the pressure- and free- and diffuse-field responses, they can be determined simply by adding corrections to the pressure response. However, to determine the necessary corrections and calibrate microphones, some institutes need to develop and gain experience with the use of the free-field calibration technique.

In principle, free-field calibration is simpler than pressure calibration, but in practice it is more difficult, as one can only obtain very low sound pressures. As no commercial free-field calibration systems are available, a few institutes have built systems themselves and succeeded in making free-field calibration a routine task. Even fewer institutes have established a calibration service.

The Danish Technical University (DTU), after several years of research, has developed a sophisticated free-field reciprocity calibration system, where Brüel & Kjær has contributed with instruments and technical modifications. This paper describes the system, which is now offered by Brüel & Kjær, with software and technical support from the university staff.

## Résumé

Même si, pratiquement, la plupart des mesurages sont réalisés dans des conditions de champ ou de champ diffus, les étalonnages des microphones de référence effectués par les centres métrologiques nationaux sont essentiellement des étalonnages de réponse en pression. Heureusement, comme la relation est fixe entre les réponses en pression et les réponses en champ libre et diffus des

microphones de mesure, il suffit pour connaître ces dernières d'ajouter les corrections idoines aux valeurs de réponse en pression. Toutefois, pour déterminer les corrections nécessaires et étalonner les microphones, certains laboratoires ont préalablement besoin d'acquérir une certaine expérience de l'étalonnage en champ libre.

Si, en principe, un étalonnage en champ libre est plus simple qu'un étalonnage en pression, il ne l'est pas dans la pratique car les pressions acoustiques mesurées sont très faibles. Comme aucun système d'étalonnage en champ libre n'est disponible dans le commerce, certains centres ont construit leur propre système et réussi à faire de l'étalonnage en champ libre une opération de routine. Un nombre très restreint de centres proposent leurs services sous forme de prestations d'étalonnage.

Au terme de plusieurs années de recherche, le centre de l'Université Technique du Danemark (DTU) a mis au point un système d'étalonnage en champ libre par méthode de réciprocité, auquel Brüel & Kjær a fourni appareillage et modifications techniques. La présente communication est une description du système Brüel & Kjær, avec logiciels et support technique de l'équipe universitaire.

## Zusammenfassung

Obwohl die meisten Messungen in der Praxis unter Freifeld- oder Diffusfeldbedingungen erfolgen, wird bei der Kalibrierung von Bezugsmikrofonen durch nationale Metrologieinstitute hauptsächlich der Druckfrequenzgang kalibriert. Dank der festen Beziehung zwischen dem Druckfrequenzgang von Messmikrofonen und den Frequenzgängen in Frei- und Diffusfeld lassen sich letztere ermitteln, indem man zum Druckfrequenzgang Korrekturen addiert. Um jedoch die erforderlichen Korrekturen ermitteln und Mikrofone kalibrieren zu können, müssen manche Institute erst eine Freifeld-Kalibrieremethode entwickeln und damit Erfahrungen sammeln.

Im Prinzip ist Freifeldkalibrierung einfacher als Druckkalibrierung, doch in der Praxis ist sie schwieriger, da man mit sehr niedrigen Schalldrücken arbeiten muss. Da Freifeldkalibriersysteme nicht kommerziell erhältlich sind, haben einzelne Institute eigene Systeme gebaut und die Freifeldkalibrierung zur Routineaufgabe gemacht. Noch weniger Institute haben einen Kalibrierdienst eingerichtet.

Die Dänische Technische Universität (DTU) hat nach mehrjähriger Forschungsarbeit ein anspruchsvolles System zur Freifeld-Reziprozitätskalibrierung entwickelt, zu dem Brüel & Kjær mit Geräten und technischen Modifikationen beigetragen hat. Dieser Artikel beschreibt das System, das jetzt von Brüel & Kjær angeboten wird, mit Software und technischer Unterstützung durch Mitarbeiter der Universität.

## Introduction

The free-field reciprocity calibration method has been applied for more than half a century. It is extensively described in literature, and the International Standard IEC 61094–3 [1] describes in detail the principle and influencing parameters. Other IEC standards belonging to the same microphone and calibration series, IEC 61094–1 [2] and IEC 61094–4 [3], describe Laboratory Standard Microphones and Working Standard Microphones, respectively. The described microphones are all condenser microphones, so they are reciprocal and suited for reciprocity calibration.

The highest calibration accuracy can be obtained with the Laboratory Standard Microphones LS1 and LS2, Brüel & Kjær Types 4160 and 4180 respectively, (see Fig. 1).

Compared to other types of microphone, these microphones have been analysed and described more thoroughly, with respect to the position of their acoustic centre [1], acoustic impedance, pressure-, temperature- and humidity coefficients [4].

A very detailed description of the method applied with the new turnkey system is given in the PhD thesis [5] of Salvador Barrera Figueroa, who performed his

*Fig. 1. Laboratory Standard Microphones Types 4160 and 4180*



study under supervision of Professors Knud Rasmussen (chairman of IEC/TC29) and Finn Jacobsen at the Danish Technical University, Kgs. Lyngby.

## Technical Challenges

The new system performs free-field reciprocity calibration by using three microphones (A, B, C), as is generally the case. For each possible microphone combination (AB, AC, BC) the transfer function is measured, while one microphone acts as a source and the other as a receiver, see Fig. 2.

Fig. 2. Principle of free-field transfer function measurement

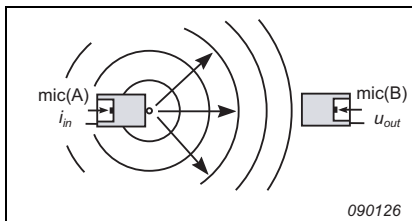

$$p_0 = \frac{\rho f}{2d} M_f i \tag{1}$$

$$p_0 = \frac{\pi \rho f^2 C u}{d} M_f \tag{2}$$

$$u_{out} = \frac{\pi \rho f^2 C u}{d} M_f(\text{source}) M_f(\text{receiver}) \tag{3}$$

where the symbols are described in Table 1.

This method is described in the IEC standard [1], but the standard does not describe how this can be performed accurately in practice (i.e., without being disturbed by reflected sound, inherent and ambient noise, and by electrical cross-talk

Table 1. Typical values of parameters used in free-field reciprocity calibration

Symbol	Parameter	Typical Value
$p_0$	Sound pressure module at a point distant from the source	–
$\rho$	Density of air	1.2 kg/m <sup>3</sup>
$f$	Frequency	–
$d$	Distance from source to the point	LS1: 400 mm LS2: 200 mm
$M_f$	Free-field sensitivity of microphone(s)	LS1: 50 mV/Pa LS2: 12.5 mV/Pa (1000 Hz)
$i$	Current through the source microphone terminals	–
$u_{in}$	Voltage between the source microphone terminals	7 V
$C$	Capacitance of the source microphone	LS1: 55 pF LS2: 20 pF
$u_{out}$	Output voltage of the receiver microphone	See Table 2

between the source and receiver measurement channels). The technical difficulties that are related to the measurement process (which are quite severe) are caused by the fact that the microphones are very weak sound sources. They need to be driven by a voltage that does not exceed 6 V to 8 V to ensure linear and non-distorted operation.

The modulus of the sound pressure produced at a point, remote from a source microphone, may be calculated by equations (1) and (2), while the output voltage of a receiving microphone, placed at this point, is given by equation (3). The outputs of LS1 (Type 4160) and LS2 (Type 4180) microphones, for typical operation distances, are calculated and shown in Table 2.

Table 2. Typical output voltage ( $\mu V$ ) of the receiver microphone during free-field reciprocity calibration

$u_{out}$ ( $\mu V$ )	500 Hz	1000 Hz	2000 Hz
LS1	2.3	9.1	36.4
LS2	0.10	0.41	1.66

As indicated by the numbers in the table, very low voltages have to be measured when calibrating microphones at these frequencies. The voltages are so low at these frequencies that they are ‘buried’ in noise generated by the system itself and noise occurring in the ambient surroundings. High sensitivity calibration accuracy requires high accuracy measurement of the output voltages (0.01 dB – 0.02 dB) and this makes the measurements both difficult and quite time consuming.

This system includes a Brüel & Kjær Multi-analyzer System Type 3560-C and software for an adaptive measurement technique called Steady State Response (SSR). The SSR measurement software records sine-signal packages that are sampled synchronously with the generator signal and averages them until a certain pre-selected accuracy of the averaged signal is achieved. This effective technique makes use of the fact that the signals measured synchronously add up arithmetically, while the non-correlated noise adds up more slowly, following the law of the root of the squares. Even if this principle is applied, it may take several minutes to perform a complex (magnitude and phase) measurement at just one of the lower frequencies, for example, 800 Hz for LS1 and 3000 Hz for LS2 microphones.

Another technical challenge is to keep cross-talk from the transmitter channel to the receiver channel low, because the receiver channel works with output voltages that may be less than 1  $\mu$ V, and the transmitter channel uses 6 to 8 V to drive the source. As the voltage ratio between the signals is about  $10^7$  (140 dB), the cross-talk should ideally be down around  $10^{10}$  (200 dB), if the result is not to be disturbed by more than 0.01 dB (approx). However, the influence of this phenomenon, and sound reflections in the measurement room (which can potentially be very significant sources of error) are minimised by the signal-processing principle described in the following section.

## Principle of Calibration

According to the IEC standard [1], the parameters of equation (4) below must be determined to obtain the sensitivity product for each of the three microphone combinations, AB, AC and BC, where A, B and C designate the microphones. After having determined and inserted the parameters, the sensitivities of all three microphones are calculated by solving the three equations.

$$M_{f,1} \cdot M_{f,2} = -j \frac{2d_{12}}{\rho f} \cdot \frac{U_2}{i_1} \cdot e^{v \cdot d_{12}} \quad (4)$$



where:

$M_{f,1}, M_{f,2}$  are the sensitivities of microphones '1' and '2'

$d_{12}$  is the distance between the acoustic centres of microphones '1' and '2'

$\rho$  is the density of air

$f$  is the frequency

$v$  is the complex sound propagation coefficient

$U_2$  is the output voltage of the receiver microphone

$i_1$  is the input current of the source microphone

The system does not, in fact, measure the current of the source microphone directly. This is determined by measuring the voltage across a series capacitor placed close to the source microphone. The transfer impedance ( $Z_{12} = U_2/i_1$ ) can, according to equation (5), be determined by a relatively simple voltage-ratio measurement and by an accurate calibration of the capacitance of the series capacitor.

$$Z_{12} = \frac{U_2}{i_1} = \frac{U_2}{U_1} \cdot (-j 2\pi f C) \quad (5)$$

where:

$Z_{12}$  is the transfer impedance of microphones '1' and '2', valid for the parameters of equation (4)

$U_1$  is the voltage across the series capacitor of source microphone '1'

$C$  is the capacitance of series capacitor of the source microphones

The voltage ratio is a function of frequency and must be measured over the frequency range of interest for the three microphone combinations. In principle, the sets of ratios only need to be measured at one microphone distance, for example, 400 mm for LS1 and 200 mm for LS2 microphones. At the primary level of calibration, national metrology institutes (NMIs) aim for an uncertainty that is as low as practically possible. Therefore, it is common to measure at more distances and obtain correspondingly more sensitive results for comparison, averaging and verification. Normally, two, three or four distances are measured.

Often it is enough to determine the frequency response of a measurement microphone with a resolution of 1/12-octave or, in some cases, even 1/3-octave. However, the processing of the voltage ratio results requires that they are measured with fixed frequency intervals, typically between 100 Hz and 140 Hz.

The fixed intervals lead to a relative resolution that is low at low frequencies and high at high frequencies. This fits well with the response slope of a microphone well, where the slope is generally steeper at high frequencies than at low frequencies.

## System Hardware

The voltage ratio measurement system is shown in Fig. 3.

*Fig. 3. Block diagram of Free-field Reciprocity Calibration System with insert voltage facility for measurement of gain difference between source and receiver channels*

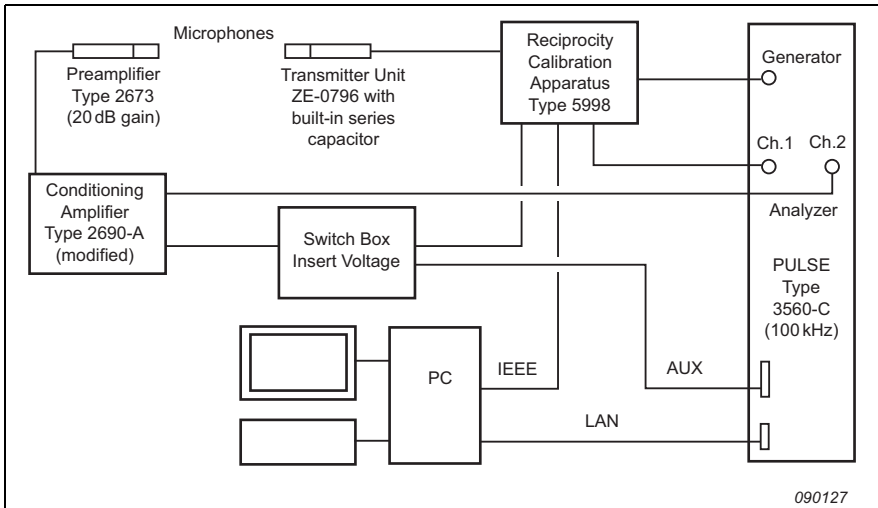

The core of the system is the Brüel & Kjaer Multi-Analyzer Type 3560-C, which has two parallel channels that measure the voltage produced by the receiving microphone, and the voltage across the series capacitor (which represents the current of the source microphone). In principle, this is what needs to be measured, but there is typically a minor gain difference between the measurement channels that also has to be measured and compensated for. This is done at each frequency by the ‘insert voltage’ facility, which is implemented in the channels.

Several steps have been taken to minimise both the inherent noise of the system and cross-talk from the source channel to the receiver channel. For these reasons, the gain of the preamplifier used with the receiver microphone is modified from its normal gain of 0 dB to 20 dB.

Reciprocity Calibration Apparatus Type 5998 is not designed for free-field calibration, but for the less demanding pressure reciprocity calibration. Therefore, even if this instrument has both a transmitter and a receiver channel, only the transmitter channel is used. To ensure good separation between the system channels, i.e., the lowest possible cross-talk, the receiver channel is equipped with a separate conditioning amplifier, Type 2690-A. To increase the immunity of the system to low-frequency ambient noise, an additional high-pass filter has been built into the conditioning amplifier.

## System Software

The system includes three dedicated software programs. The first is the measurement software that sets up the hardware according to preselected input parameters, automatically controls all measurements, and stores the measurement results. The second program calculates the sensitivities in accordance with IEC 61094-3 [1]. Knud Rasmussen and Salvador B. Figueroa developed both programs during their time with the Technical University of Denmark (DTU) and the Danish Institute of Fundamental Metrology (DFM). The output of the calculation program is the complex sensitivities valid at standard conditions. The result for each measurement distance result is stored in a separate file. The third program allows you present the results by loading selected files into standard office programs for comparison and for report preparation.

## Processing of Measured Voltage Ratios

The series of voltage ratio results to be processed are all measured at multiples of a preselected frequency step, which is typically 120 Hz. The measurements themselves typically cover the ranges from about 1000 Hz to 31 000 Hz for LS1 microphones, and from 3000 Hz to 51 000 Hz for LS2 microphones. There are always three files for each measurement distance and typically two to four distances. A sensitivity result will be obtained for each distance. The whole series of measurement results are to some degree ‘contaminated’ by disturbing acoustic reflections, and these influences need to be removed. To ‘clean up’ the data, the whole measurement series needs to be extended with additional data down to 0 Hz and up to about 51 000 kHz for LS1 and 70 000 Hz for LS2.

At low frequencies, the calculation of the additional data for each series is based on the individual 250 Hz pressure sensitivities of the two applied microphones,

and on DTU/DFM experienced data, describing the uniform, low-frequency responses of the LS1 and LS2 microphones, Types 4160 and 4180. At high frequencies, the series is already extended by measuring to frequencies above the normal operation ranges of the microphones. Further data is calculated by considering that the pressure responses ‘roll off’ by 12 dB/octave.

The principle of the signal ‘cleaning’ process is illustrated in Fig. 4.

Fig. 4. Principle of ‘cleaning’ voltage-ratio frequency responses from the influence of sound reflections

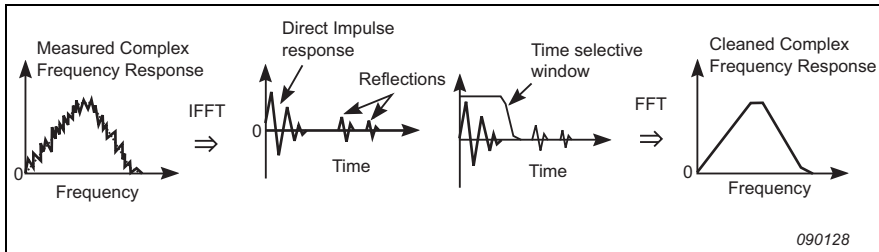

090128

The first step of the procedure is to find the impulse response of the two acoustically coupled microphones by creating an inverse FFT of the extended voltage ratio frequency response (see a true result in Fig. 5).

The response has a clear separation in time between the directly arriving sound and the delayed (and disturbing) sound reflections. The part of the impulse that belongs to the reflections is now removed by applying a time window. The results are then converted back to the frequency domain by performing FFT, creating the filtered voltage ratio transfer function, without the influence of reflections.

After ‘cleaning’ the transfer functions, the complex sensitivities of the microphones are calculated for each measurement distance in accordance with equations (4) and (5). When measurements are made with more than one distance, the average responses can be calculated for both magnitude and phase and presented as the result of the calibration.

The software used with the system accounts for the position of the acoustic centre of the microphones. The centre position is a function of frequency. For low frequencies and for the axial sound incidence, the centre for LS1 microphones is about 9 mm in front of the diaphragm. As frequency increases, it moves closer to the diaphragm until it reaches the diaphragm at 8–10 kHz. It continues to move past the diaphragm as frequency increases and is positioned a few millimetres behind the diaphragm at higher frequencies. For LS2 microphones, the

Fig. 5. True transfer time function for a pair of LS1 microphones ( $d = 250$  mm)

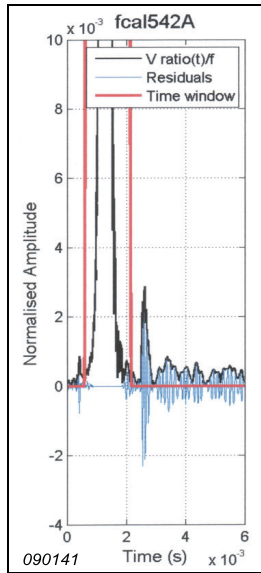

corresponding numbers are 4.5 mm and 20–22 kHz. Centre position data is included in the software, but the positions are also estimated by the system itself, if measurements are made at three or more distances. For reasons of transparency, the software stores measurement files, extended measurement files, acoustic centre files and result files in linear and logarithmic frequency steps. The linear frequency steps are equal to the measurement steps. Results for logarithmic steps are determined by linear interpolation with a resolution of 1/12-octave.

## Sensitivity Calibration Results

Free-field calibration results are in general obtained from 250 Hz to 31080 Hz for LS1, and from 250 Hz to 51120 Hz for LS2. Fig. 6 shows typical magnitude and phase response results for LS2 (Type 4180). It should be noted that these calibrations only comply with the international standard IEC 61094–3 within the frequency range covered by the true free-field measurements that, for DPLA, generally starts at around 1000 Hz for LS1 and at 3000 Hz for LS2.

Fig. 6. Measured magnitude and phase of the free-field response – Type 4180 No. 1395445

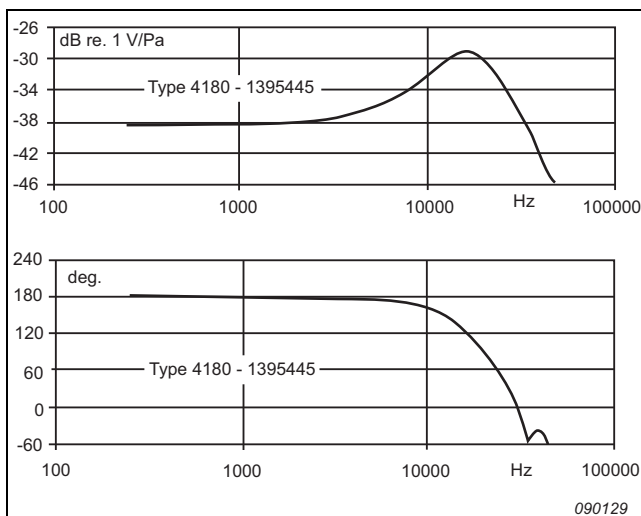

However, the determination of the low-frequency extensions to the measured voltage-ratio series is also based on certain standards from the IEC 61094 series. DPLA measures the individual pressure sensitivities at 250 Hz in accordance with IEC 61094–2. The microphone responses from 250 Hz to the lowest measurement frequencies are based on IEC standards, partly IEC 61094–2 [6] and partly IEC 60194–7 [7], which specifies free-field corrections for perpendicular incidence on LS microphones. The file extensions and the low-frequency responses, therefore, also rely on standards and solid knowledge.

It should also be stated that free-field measurements can be made at frequencies that are lower than those already mentioned, but this would lead to a drastically extended measurement time. In fact, the measurements at just a few of the lowest frequencies may last longer than those at all other frequencies in the series. No significant differences and improvements have been observed by measuring down to lower frequencies, so the previously mentioned start frequencies have been found to be a good compromise. At the high end of the frequency range, measurements are made beyond the normal operation range of the microphones. This is done because it slightly influences and improves the accuracy of the method at the highest frequencies within the range of interest. Valid results can be obtained up to about 24 kHz for LS1, and up to about 48 kHz for LS2. These limits

are not set by the system, but rather by the microphones, whose frequency responses are not smooth beyond the frequencies mentioned.

An LS2 calibration made at one measurement distance will typically take 2 hours, while a thorough calibration made at four measurement distances will take a full day. Both calibrations will, of course, result in free-field responses for each of the three microphones that were included in the process. LS1 calibration requires half the time.

## Estimated Calibration Uncertainty

The free-field reciprocity calibration system described in this paper is very similar to the system from Danish Fundamental Metrology (DFM) who, together with Brüel & Kjær, operate the Danish Primary Laboratory of Acoustics (DPLA). This laboratory has accreditation to perform free-field calibrations of LS1 and LS2 microphones in accordance with IEC 61094–3. The uncertainty encountered by DFM/DPLA is specified for the two types of microphone in Table 3 and Table 4.

*Table 3. Estimated uncertainty of free-field calibration result for Type 4160 (LS1)*

<b>LS1</b>	<b>0.25 – 1.19 kHz</b>	<b>1.2 – 15 kHz</b>	<b>15.1 – 17.9 kHz</b>	<b>18 – 21 kHz</b>	<b>21.1 – 24 kHz</b>
Type 4160 DFM/DPLA accredited	–	0.07 dB	0.08 dB	0.09 dB	–
New user of system	0.12 dB	0.11 dB	0.12 dB	0.14 dB	0.25 dB

*Table 4. Estimated uncertainty of free-field calibration result for Type 4180 (LS2)*

<b>LS2</b>	<b>0.25 – 2.99 kHz</b>	<b>3 – 9.98 kHz</b>	<b>10 – 23.9 kHz</b>	<b>24 – 32 kHz</b>	<b>32.1 – 48 kHz</b>
Type 4180 DFM/DPLA accredited	–	0.07 dB	0.09 dB	0.12 dB	–
New user of system	0.12 dB	0.11 dB	0.14 dB	0.18 dB	0.30 dB

For a new user of the free-field system, it is assumed that the uncertainty will be around 50% higher, until the user has built up experience and detailed knowledge about the topic.

Generally, DFM/DPLA perform calibrations at several microphone distances. Compensation is made for acoustic centre positions and for propagation-loss in the air, so, if the distances are within the tested and verified range for the combination of system settings and the acoustic measurement room, then ideally, there should be no difference between the results obtained. The purpose is partly to gain

accuracy by performing a final averaging of (typically) four results, and partly to verify that the microphones and the instruments are stable and working properly, while the measurements are being performed. Another advantage of performing more measurements at multiple distances is that this prevents mistakes that may be made during system setup and microphone mounting. Fig. 7 shows typical deviations between four results for Type 4180 (No. 1503934) that were obtained on the same day at the following distances: 170 mm, 200 mm, 240 mm and 300 mm.

*Fig. 7. Deviations between the results of four free-field reciprocity calibrations performed at four different distances – Type 4180 No. 1503934. All results are shown relative to their common mean value*

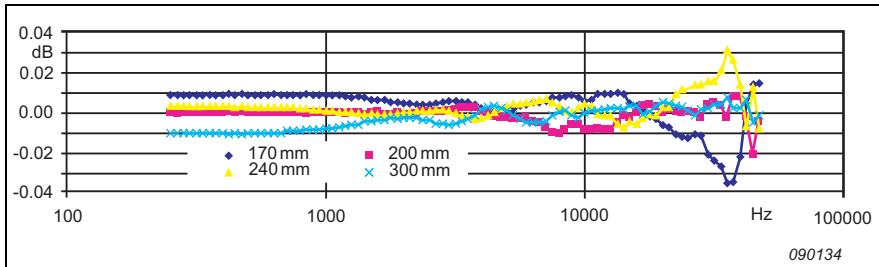

## Anechoic Measurement Room

The voltage-ratio measurements do not, in principle, need to be performed in an anechoic room, due to the time-selective measurement technique that the system employs. The time window, applied with the post-processing, will exclude the influence of reflections arriving from points that are more than 250–300 mm from the two microphones. However, the much stronger reflections that would occur in a normal room, without damping material, would ‘contaminate’ the measurement results.

There are a couple of reasons for using an anechoic room. The first is that the calculation of the low-frequency extensions and their linking to the measured data would become very difficult and far less precise. The second is that a closed chamber with damping material helps to keep the noise level of the background low. The anechoic room can be relatively small, however, less than 2 m<sup>3</sup>, and not necessarily of the highest standard. The dimensions of the free space in the room used by DFM/DPLA was 0.8 m × 1.25 m × 1.7 m, see Fig. 8. The wedges on the walls were 300 mm long. The DFM microphone positioning system is computer



*Fig. 8. The DFM/DPLA free-field calibration room. The microphone mounting bars were automatically moved between pre-selected microphone positions (In front: Knud Rasmussen)*



controlled. Use of a small anechoic room facilitates more accurate and stable mounting than a large room.

## Summary

This paper describes an elaborate free-field reciprocity calibration system for laboratory standard and measurement microphones. Members of the Technical University of Denmark and Danish Fundamental Metrology have developed the methods and the signal processing software, while Brüel & Kjær has contributed with both dedicated and standard instruments, and software.

In addition to its low-noise amplifiers, the system uses the SSR-measurement technique for suppression of disturbing noise. It also uses a time selective signal processing method that minimises the influence of sound reflections and cross-talk. Furthermore, the method reduces the requirements of the quality of the acoustic measurement room. The result is a system that works quickly and gives highly repeatable results with low uncertainty. This is especially true for the Laboratory Standard Microphones Types 4160 (LS1) and 4180 (LS2), as the software contains correction data for acoustic centre positions and ambient conditions for these microphone types.

## Acknowledgements

Thanks to Knud Rasmussen and Salvador B. Figueroa of DFM, Kgs. Lyngby, Denmark, for supplying details about the operation principle and about the results obtainable with the method and system described in this paper. The system is based on their research, method development and on their many years of experience with microphone calibration.

## References

- [1] IEC International Standard 61094-3, “*Measurement Microphones, Part 3: Primary Method for Free-field Calibration of Laboratory Standard Microphones by the Reciprocity Technique*”, Int. Electrotechnical Commission, Geneva, November 1995.
- [2] IEC International Standard 61094-1, “*Measurement Microphones, Part 1: Specifications for Laboratory Standard Microphones*”, Int. Electrotechnical Commission, Geneva, July 2000.
- [3] IEC International Standard 61094-4, “*Measurement Microphones, Part 4: Specifications for Working Standard Microphones*”, Int. Electrotechnical Commission, Geneva, November 1995.
- [4] Knud Rasmussen, “*The Static Pressure and Temperature Coefficients of Laboratory Standard Microphones*”, *Metrologia* 36, pp 265–273, 1999.
- [5] Salvador B. Figueroa, “*New Methods for Transducer Calibration: Free-field Reciprocity Calibration of Condenser Microphones*”, PhD Thesis, Ørsted, DTU, Technical University of Denmark, 2003.
- [6] IEC International Standard 61094-2, “*Measurement Microphones, Part 2: Primary Method for Pressure Calibration of Laboratory Microphones by the Reciprocity Technique*”, Int. Electrotechnical Commission, Geneva, February 2009.
- [7] IEC International Standard 61094-7, “*Measurement Microphones, Part 7: Values for the Difference Between Free-field and Pressure Sensitivities of Laboratory Standard Microphones*”, Int. Electrotechnical Commission, Geneva, May 2006.

# Previously Issued Numbers of Brüel & Kjær Technical Review

*(Continued from cover page 2)*

- 1 – 1996 Calibration Uncertainties & Distortion of Microphones.  
Wide Band Intensity Probe. Accelerometer Mounted Resonance Test
- 2 – 1995 Order Tracking Analysis
- 1 – 1995 Use of Spatial Transformation of Sound Fields (STSF) Techniques in the  
Automotive Industry
- 2 – 1994 The use of Impulse Response Function for Modal Parameter Estimation  
Complex Modulus and Damping Measurements using Resonant and Non-  
resonant Methods (Damping Part II)
- 1 – 1994 Digital Filter Techniques vs. FFT Techniques for Damping Measurements  
(Damping Part I)
- 2 – 1990 Optical Filters and their Use with the Type 1302 & Type 1306 Photoacoustic  
Gas Monitors
- 1 – 1990 The Brüel & Kjær Photoacoustic Transducer System and its Physical  
Properties
- 2 – 1989 STSF — Practical Instrumentation and Application  
Digital Filter Analysis: Real-time and Non Real-time Performance
- 1 – 1989 STSF — A Unique Technique for Scan Based Near-Field Acoustic  
Holography Without Restrictions on Coherence
- 2 – 1988 Quantifying Draught Risk
- 1 – 1988 Using Experimental Modal Analysis to Simulate Structural Dynamic  
Modifications  
Use of Operational Deflection Shapes for Noise Control of Discrete Tones
- 4 – 1987 Windows to FFT Analysis (Part II)  
Acoustic Calibrator for Intensity Measurement Systems
- 3 – 1987 Windows to FFT Analysis (Part I)

## Special Technical Literature

Brüel & Kjær publishes a variety of technical literature which can be obtained from your local Brüel & Kjær representative.

The following literature is presently available:

- Catalogues (several languages)
- Product Data Sheets (English, German, French, Italian, Spanish)

Furthermore, back copies of the Technical Review can be supplied as listed above. Older issues may be obtained provided they are still in stock.



**BRÜEL & KJÆR | LISTEN... FEEL.. SOLVE.**

[www.bksv.com](http://www.bksv.com)

HEADQUARTERS: Brüel & Kjær Sound & Vibration Measurement A/S  
DK-2850 Nærum · Denmark · Telephone: +45 77 41 2000 · Fax: +45 45 80 1405  
[www.bksv.com](http://www.bksv.com) · [info@bksv.com](mailto:info@bksv.com)

Local representatives and service organisations worldwide

**Brüel & Kjær**   
Incorporating LDS and Lochard



BV 0061 - 11 ISSN 0007-2621